



REC^{smart+}

Decentralized Heat Recovery Unit

Single rooms up to 40 m²



Comply with ErP Directive 2009/125/CE and EU Regulation 1253/2014.
Residential Ventilation Unit.

- **Integrated Humidity Control**
- **Thermal efficiency up to 75%**
- **Easy to install: no ducting system or heavy masonry required.**
A hole of \varnothing 100 mm is sufficient.
- **Ideal for refurbishment and energy requalification.**
- **Drastic solution to humidity and condensate problems.**
- **EC motors.**

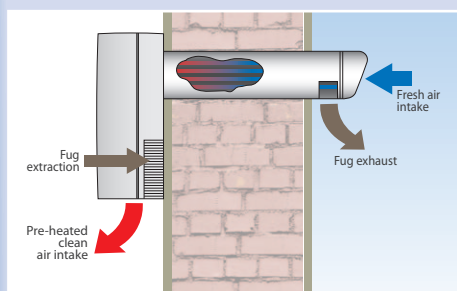

- Tubular heat exchanger with separate flows for a perfect hygiene.
- Balanced double flow, 24/7 running.

REC^{smart+} RC



REC^{smart+} TC

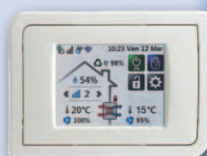

DESCRIPTION

- **REC^{smart+}** is available in a range of 3 models corresponding to 3 different duct length, with a unique duct diameter 100 mm. The measures reported on the dimensional drawing refer to the maximum thickness of the wall on which the ventilation unit can be installed: 400, 500, 600 mm.
- 3 models with duct \varnothing 100 mm and 3 standard lengths for wall thickness up to 600 mm.
- Suitable for any kind of room. Ideal for wet rooms like kitchens and bathrooms.
- Extremely compact and versatile: can be installed in horizontal or vertical position.
- High energy saving thanks to EC motors
- Integrate by-pass and antifreeze functions.
- Provided with 3 filters: the air is filtered in both flows before entering the heat exchanger.
- Easy maintenance and cleaning: filters and heat exchanger are removable and washable.
- Comply with EN 60335-2-80, B.T. 2006/95/CE, EMC 2004/108/CE.

OPERATION

REC^{smart+} is designed for a 24 hours running at the minimum speed. The unit switches at the highest speed through a manual command on a remote controller (remote switch / push button, radio controller or Touch Panel) or automatically (through the integrated humidity sensor or via the Touch Panel weekly programming).

Both models RC and TC are provided with the MHY Smart humidity control (a technology patented by Maico Italia) which allows to have the ventilation speed automatically set according to the detected humidity level.

The BOOST function (maximum speed) is provided with a timer (adjustable from 0 to 30 minutes) that can be activated through remote controller (switch, light switch, radio controller, touch panel). The function is useful in case it is necessary to have the unit running at the maximum speed independently from the humidity level.

MODELS

REC^{smart+} RC

The model is supplied with a remote radio controller. The ventilation unit is provided with 3 LED that indicate the operation modality, including the sleep mode and the extraction mode, as well as the indication of potential anomalies.

Through the remote radio controller it is possible to manage the following functions:

- On/Off
- The Speed/ventilation level regulation
- The Sleep modality that allow to have the unit running silently at low speed during the night (the boost function is excluded)
- The post-ventilation function (Timer function, adjustable from 0 to 30 minutes) to delay the switching of the unit at the minimum speed

REC^{smart+} TC

The model is supplied with a remote Panel Touch controller with coloured screen. The ventilation unit is provided with 3 LED that indicate the operation modality, including the sleep mode and the extraction mode, as well as the indication of potential anomalies.

The Touch Panel allows to manually or automatically manage (through the weekly programming) the following functions:

- The Speed/ventilation level regulation
- The ventilation modality (by-pass function, free-cooling, only extraction, only immission)
- The threshold humidity level over which the unit increases its speed
- The post-ventilation function (Timer function, adjustable from 0 to 30 minutes) to delay the switching of the unit at the minimum speed)
- The Sleep modality that allow to have the unit running silently at low speed during the night (the boost function is excluded)

PERFORMANCE

MODEL	DUCT	WALL THICKNESS	Volt a 50 Hz	m³/h	l/s	W	A	dB (A)	
	∅	max						LwA	LpA*
RC REC Smart+ Radio Control									
REC ^{smart+} L400 + REMOTE CONTROL	100	400	230	27/53	8 / 15	8,3 / 28,3	0,075 / 0,207	48,3 / 59,4	27,7 / 39,3
REC ^{smart+} L500 + REMOTE CONTROL	100	500	230	27/53	8 / 15	8,3 / 28,3	0,075 / 0,207	48,3 / 59,4	27,7 / 39,3
REC ^{smart+} L600 + REMOTE CONTROL	100	600	230	27/53	8 / 15	8,3 / 28,3	0,075 / 0,207	48,3 / 59,4	27,7 / 39,3
TC REC Smart+ Touch Control									
REC ^{smart+} L400 + PANNELLO TOUCH	100	400	230	27/53	8 / 15	8,3 / 28,3	0,075 / 0,207	48,3 / 59,4	27,7 / 39,3
REC ^{smart+} L500 + PANNELLO TOUCH	100	500	230	27/53	8 / 15	8,3 / 28,3	0,075 / 0,207	48,3 / 59,4	27,7 / 39,3
REC ^{smart+} L600 + PANNELLO TOUCH	100	600	230	27/53	8 / 15	8,3 / 28,3	0,075 / 0,207	48,3 / 59,4	27,7 / 39,3

* at 3 m in open field

DIMENSIONS (mm)

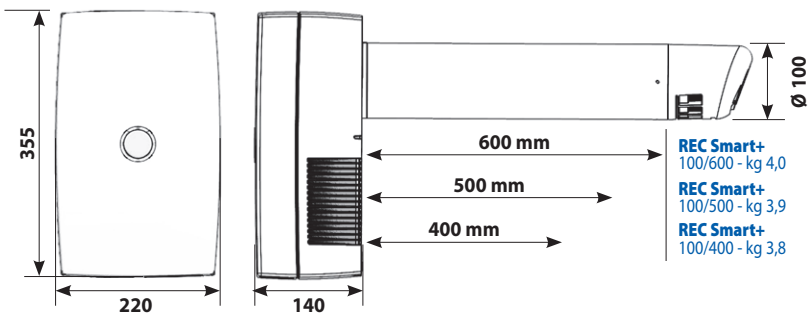

INSTALLATION

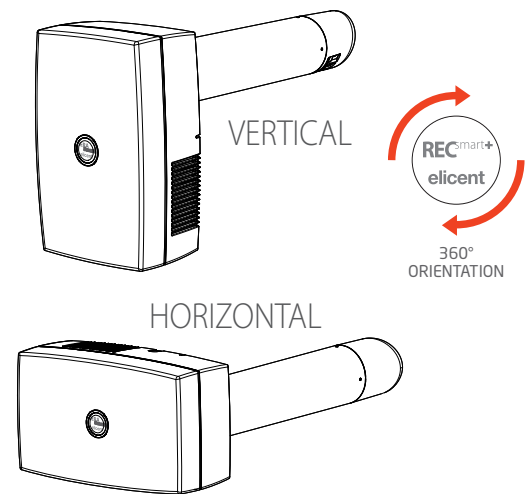

BEFORE



AFTER